



Model T15/16/16  
Model T15/32/32

# USER MANUAL

Revision 1.6

---



---

# Contents

Overview	4
Specification	5
Drawings	6
Software installation	
Basics	7
Advanced	8
Getting started	9
Software operation	
Basics	10
Region of interest	12
Options	13
Normalization	15
Background compensation	16
Saving image	17
Recording video	18
Difference mode	19
Working area	20
Maintenance	22
Troubleshooting	23

## Notation



left-click



click-and-  
drag



right-click

# Overview

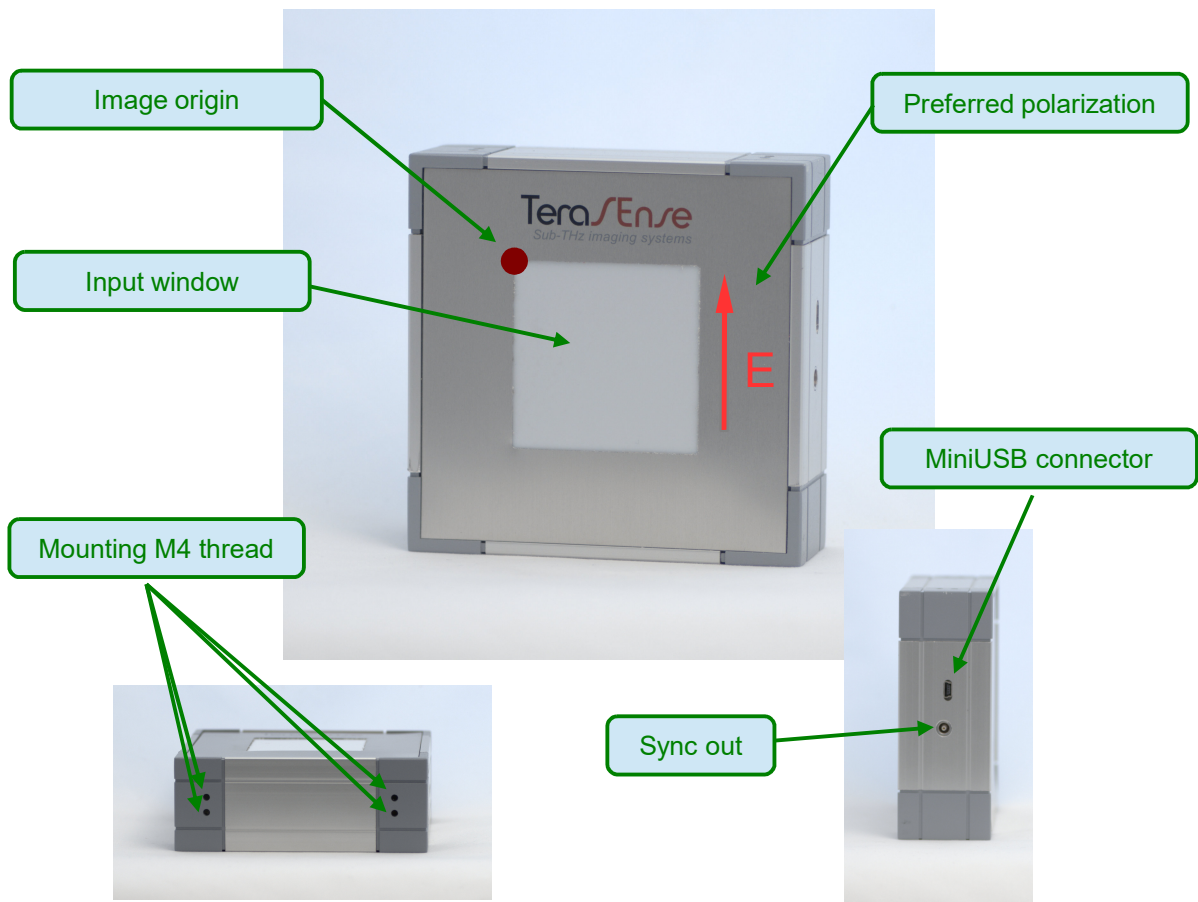

\*\*\* actual appearance may be different from the one shown

Terasense™ camera models T15/16/16 and T15/32/32 are compact sub-THz imaging sensors operating at room temperature. They have multiple sensitivity bands in the range of approximately 50-700 GHz (specific frequency dependence may vary for different devices according to customer's specification).

Camera is sensitive to polarization of incoming radiation. Preferred direction of electric field is indicated in the figure.

The devices use PC (connected via USB) for data acquisition and processing. Only Windows operating system is supported at the moment. Performance of the camera may be affected by performance of the PC, it is recommended to use PC with CPU score in Windows Experience Index of at least 5.

The cameras are powered by USB, no external power supply is needed.

---

# Specification

Dimensions: 100x100x55 mm

Sensor size: 48x48 mm, 32x32 pixels (model T15/32/32)

24x24 mm, 16x16 pixels (model T15/16/16)

Connection: miniUSB

Sync output 5V TTL (LEMO 00.250 series socket)

Power: USB-powered

Operating conditions: 15 to 30°C, humidity < 80%

Storage conditions: -30 to 45°C, humidity < 90%

## Exposure parameters

exposure	0	1	2	3	4	5	6	7	8	9	10
framerate, fps	90	85	52	24	14	7.7	3.6	1.9	0.9	0.45	0.23
relative amplification	1	2.8	6.3	13	28	56	113	226	453	906	1813

## Sync out waveform

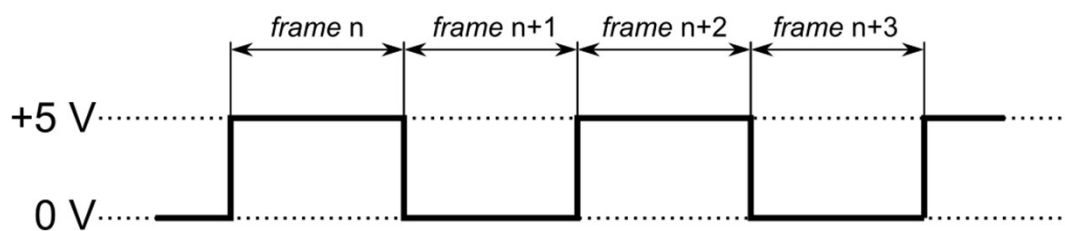

# Drawings

TERA-1024 model T15/32/32

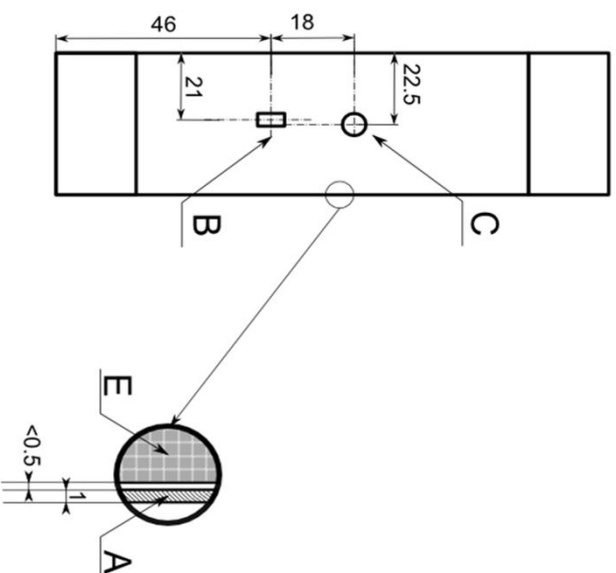
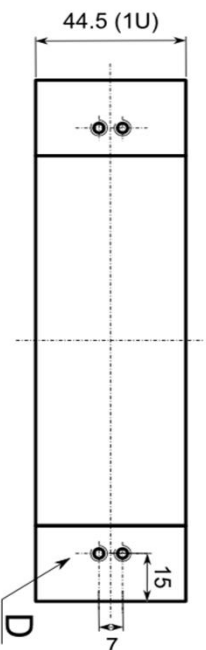
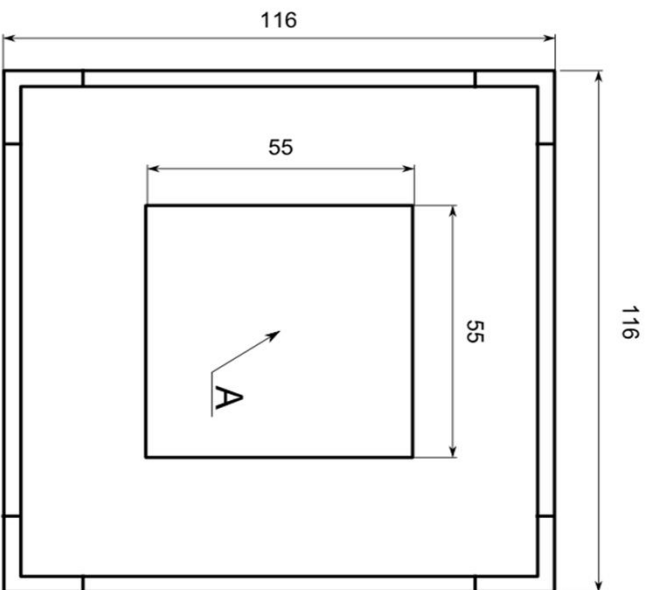

- A - PTFE window
- B - data connector (miniUSB socket)
- C - sync out (LEMO 00 socket)
- D - mounting holes (M4, 4 holes on top and bottom)
- E - sensor's surface

# Software Installation

## Basic



If you are already using Python software, please, see next page

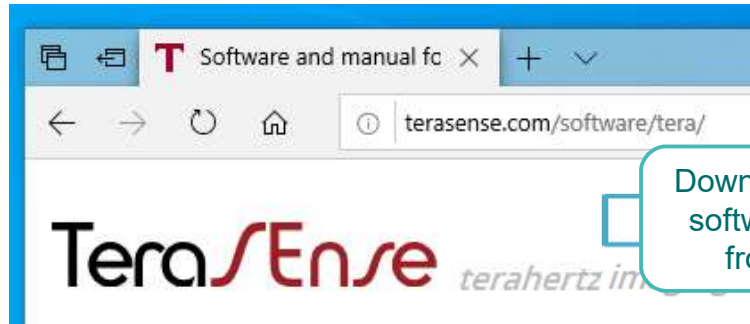

Download complete software package from our site



Unzip to a temporary location

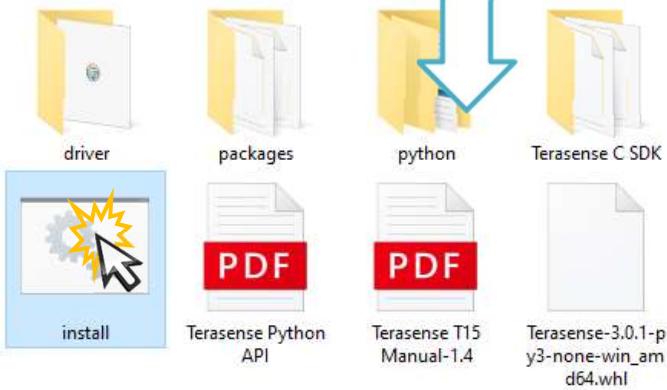

Double-click the batch file

Confirm you want the install.  
Give UAC permissions if asked

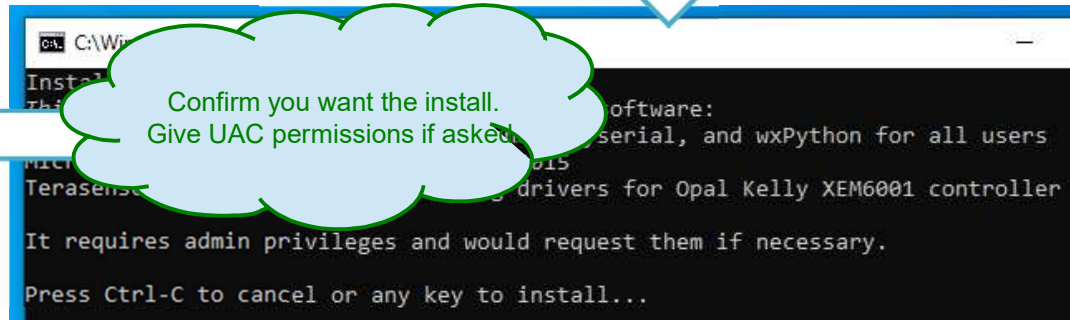

Congratulations, you are done!

TSV (TeraSense Viewer) icon is created on your desktop.  
You may also start it as "TSV.pyw" from the command line.

# Software Installation

## Advanced

TeraSense software (starting from version 3.0.1) works with Python 3.x, either 32 or 64 bit. It is packaged as a wheel and depends on the following packages:



If you have Python 3.x already installed you may download just a corresponding wheel package from our site (or use the one supplied on a thumb-drive) and install it from a command line as (substitute correct version of the wheel file):

```
>pip3 install Terasense-3.0.1-py3-none-win_amd64.whl
```

Missing dependency packages, if any, would be downloaded and installed by PIP automatically (you may also find them either on the thumb-drive or in the full package). Depending on your Python installation, you may need run the command line as administrator in order for PIP have enough rights to modify it.

```
Administrator: Command Prompt - pip3 install Terasense-3.0.1-py3-none-win_amd64.whl
C:\Users\testt\Documents\Terasense-3.0.1-full>pip3 install Terasense-3.0.1-py3-none-win_amd64.whl
Processing c:\users\testt\documents\terasense-3.0.1-full\terasense-3.0.1-py3-none-win_amd64.whl
Collecting wxPython (from Terasense==3.0.1)
  Downloading https://files.pythonhosted.org/packages/5f/ea/caa45a9b3f52fd818526edf5e665c4010d82693845cc1702710112e3b0c0/wxPython-4.0.7.post2-cp38-cp38-win_amd64.whl (22.9MB)
    | 4.9MB 345kB/s eta 0:00:53
```

When software installation finishes, connect your device to PC using USB-miniUSB cable and wait for Windows installing driver for the device controller (Opal Kelly XEM6001).

After the installation you may run the program as “TSV.pyw” from a command line, however you won’t get a shortcut on the desktop. Create it either by using “create shortcut.bat” or manually – the script is located at \Python3x\Scripts\TSV.pyw and the icon is located at \Python3x\Lib\site-packages\terasense\gui\tera.ico

**TeraSense software may or may not work with earlier versions of the prerequisite packages. Consult our support for more information.**



# Getting started



Connect device to PC using USB cable

Run TeraSense software



Opal Kelly  
XEM6001

TeraSense camera appears in the  
“Devices and Printers” window as  
“Opal Kelly XEM6001”

When connecting for the first time to a new PC you'll need to wait while Windows installing drivers for the device.

TeraSense camera is sensitive to changes in temperature. If you bring camera from a cold or hot place, please, wait until its temperature comes into balance and you'll likely need to take new recording of background data (see p.13).

# Software operation

## Basics

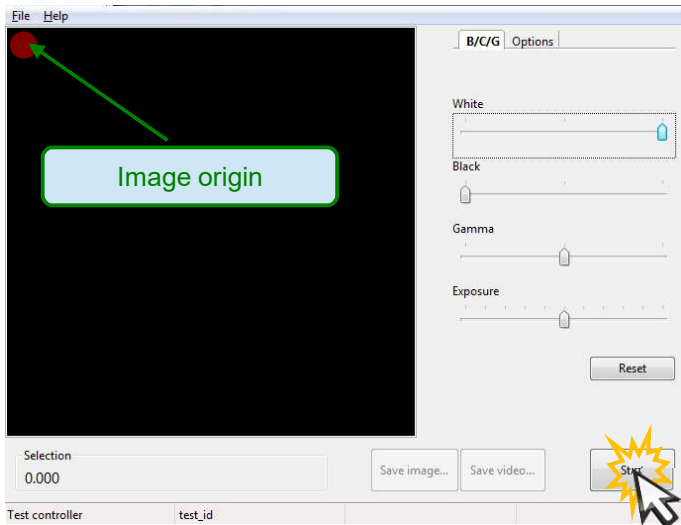

Data acquisition begins

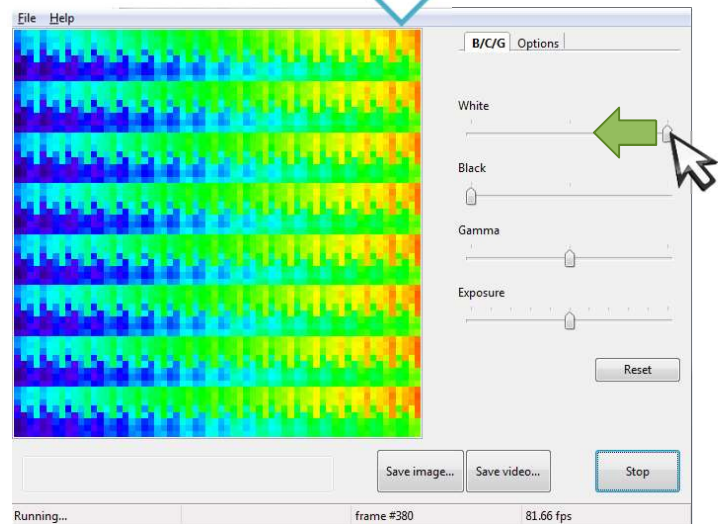

Brightness and contrast are adjusted (white point)

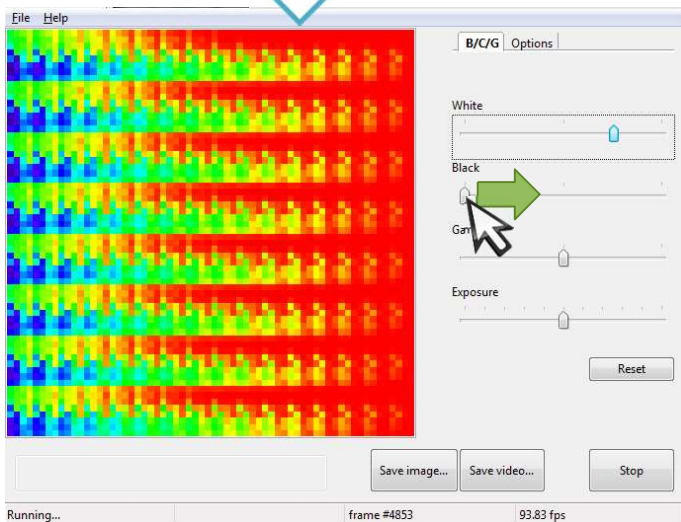

Brightness and contrast are adjusted (black point)

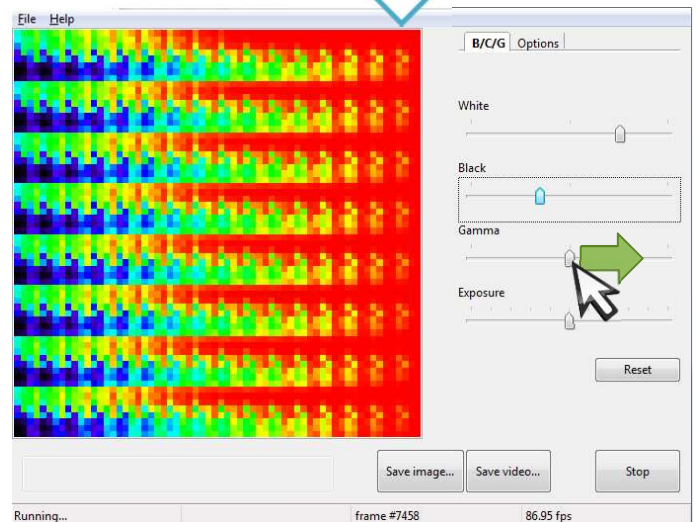

Gamma is adjusted

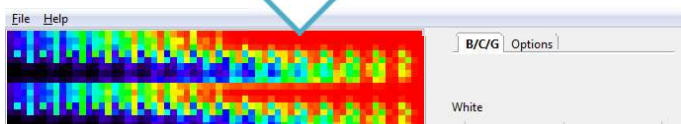

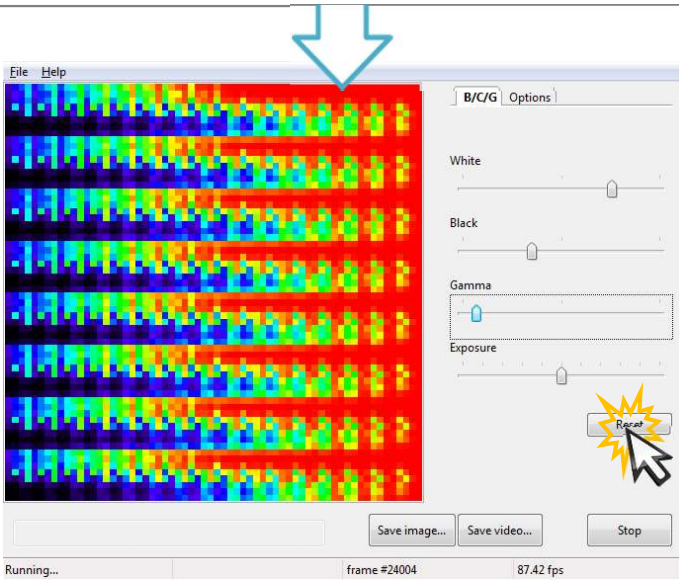

White point, black point, and gamma are reset to default

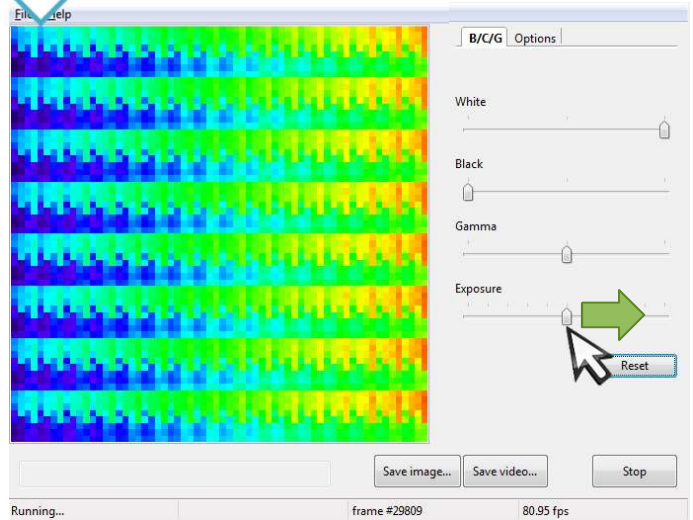

Exposure is changed

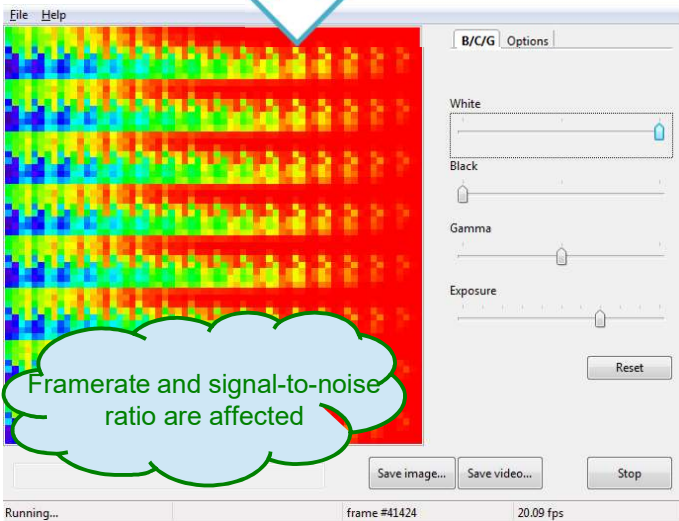

Framerate and signal-to-noise ratio are affected

- One step corresponds to 2x change in exposure.
- Maximum framerate (at shortest exposure) is about 50 fps

# Software operation

## Region of interest

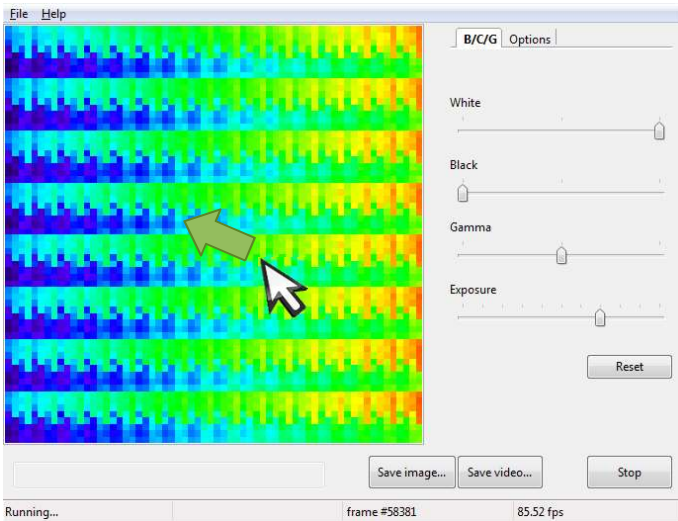

Click-n-drag selects a region in the image

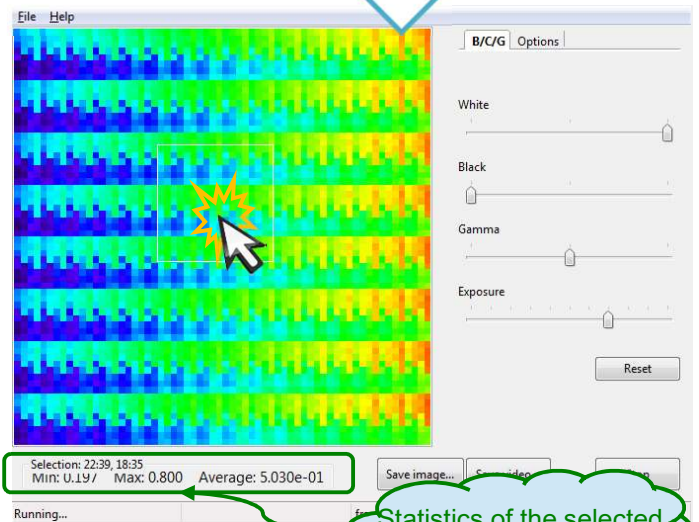

Statistics of the selected region

Left-click selects single point

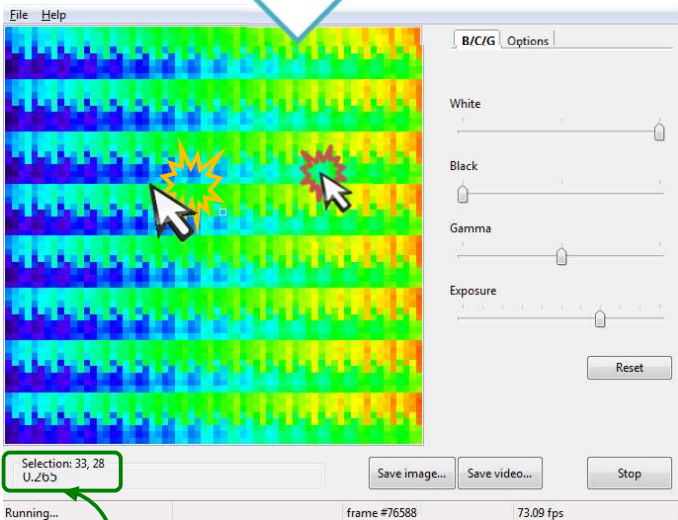

Coordinates and value at the point

Right-click removes selection

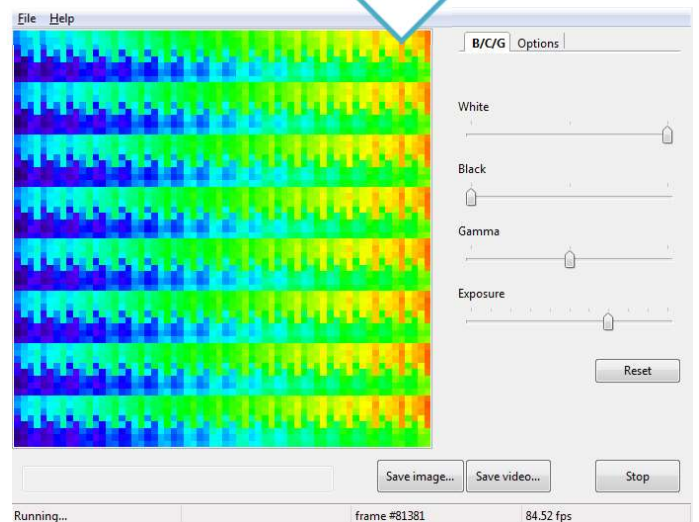

# Software operation

## Options

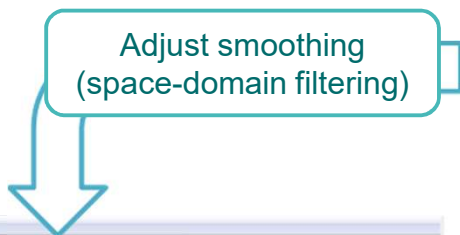
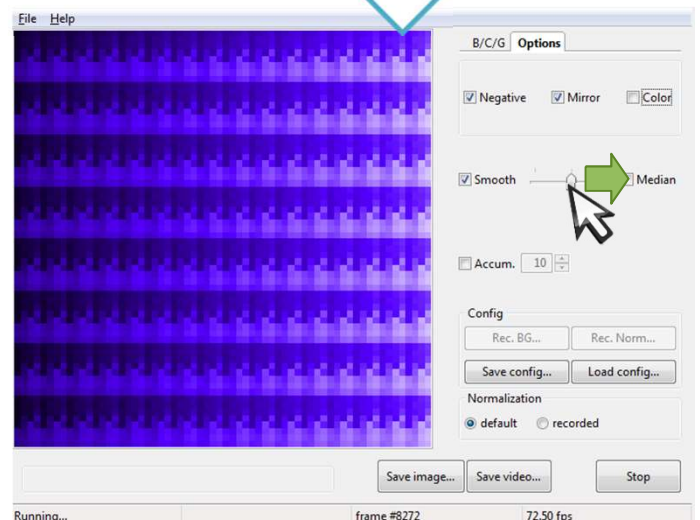
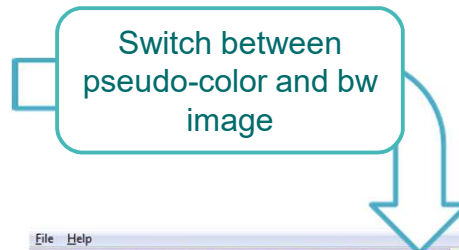
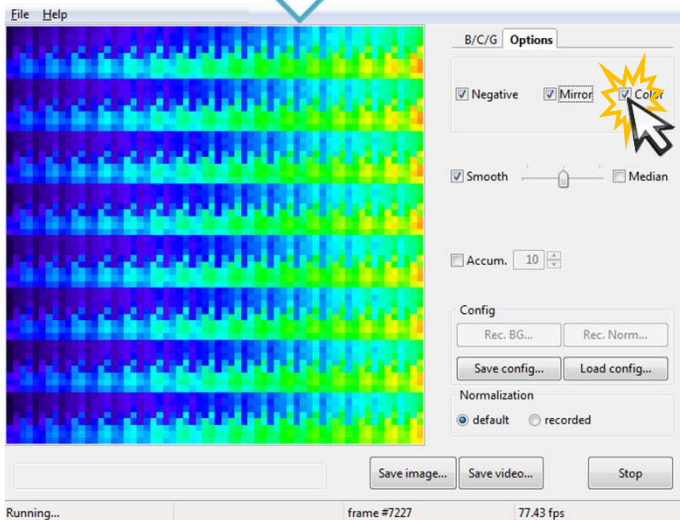
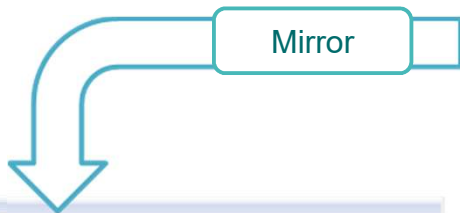
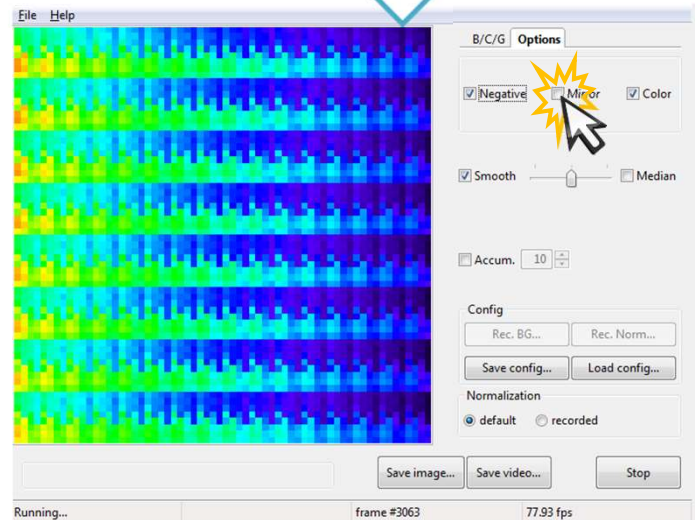
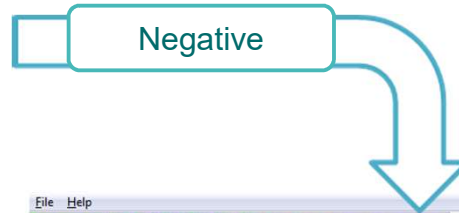
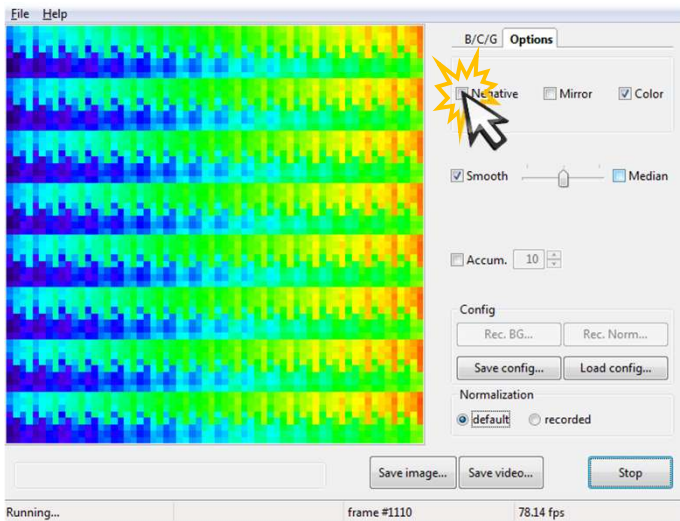

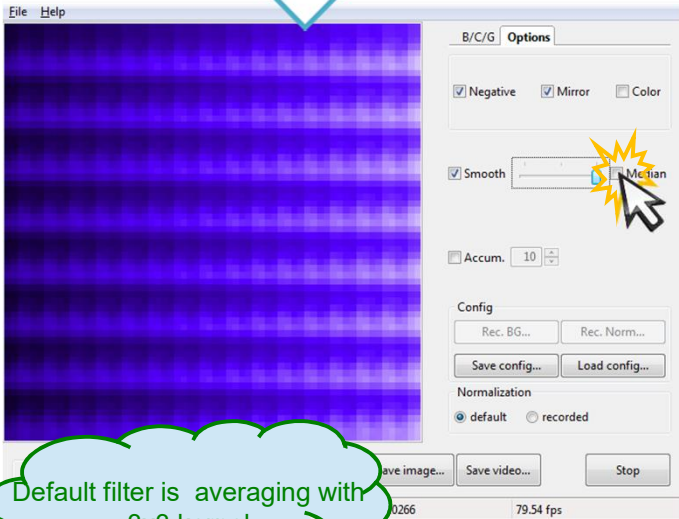

Default filter is averaging with 3x3 kernel

Median filter

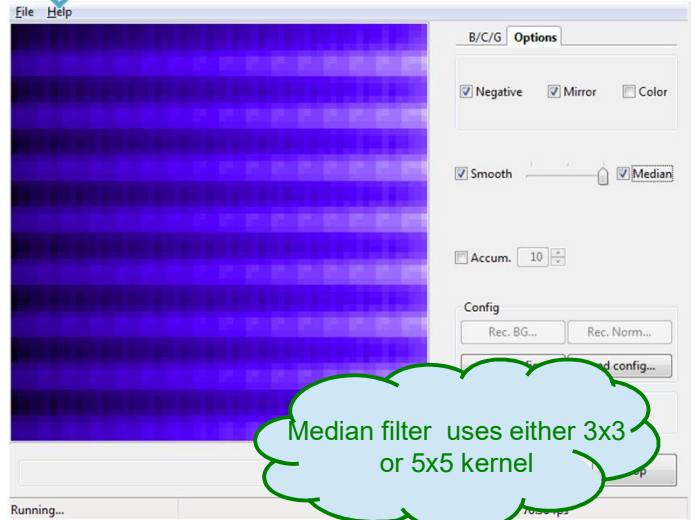

Median filter uses either 3x3 or 5x5 kernel

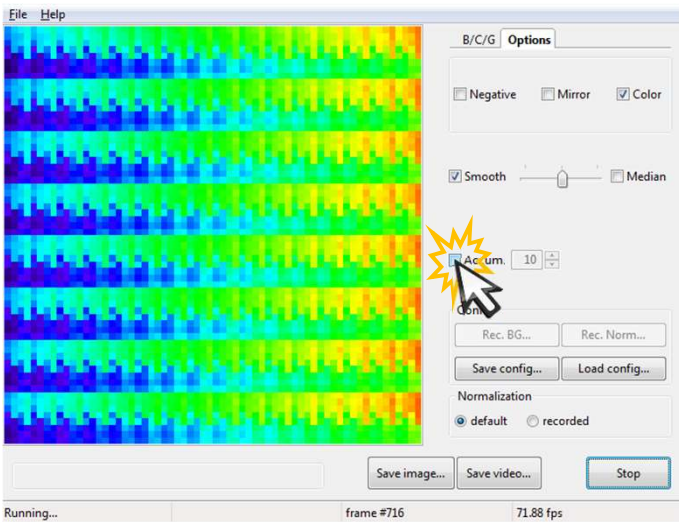

Accumulation  
(time-domain  
filtering)

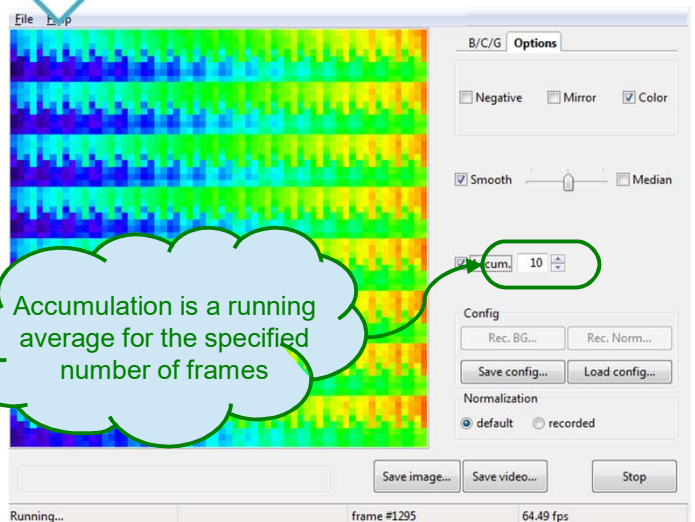

Accumulation is a running average for the specified number of frames

# Software operation

## Normalization

(compensation for beam profile)

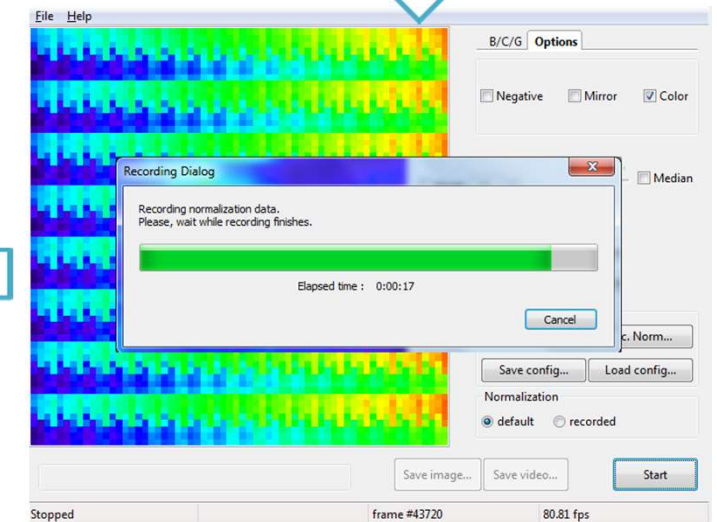
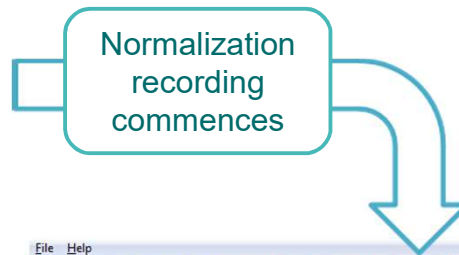
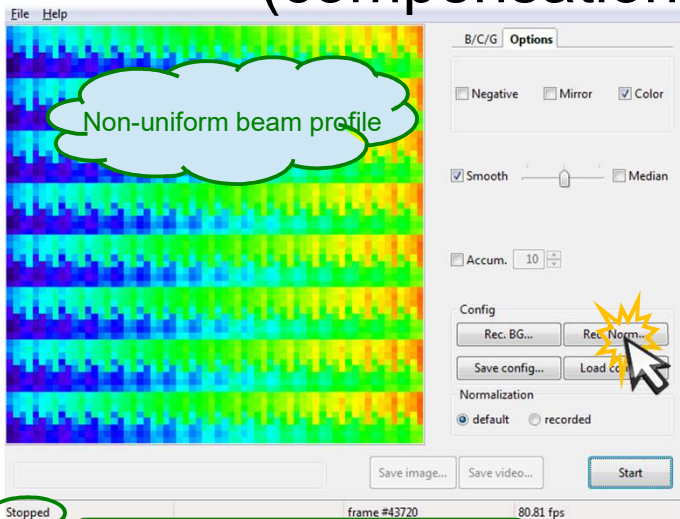

Stopped  
frame #43720 80.81 fps

"Rec Norm..." button is active only when no acquisition is running.

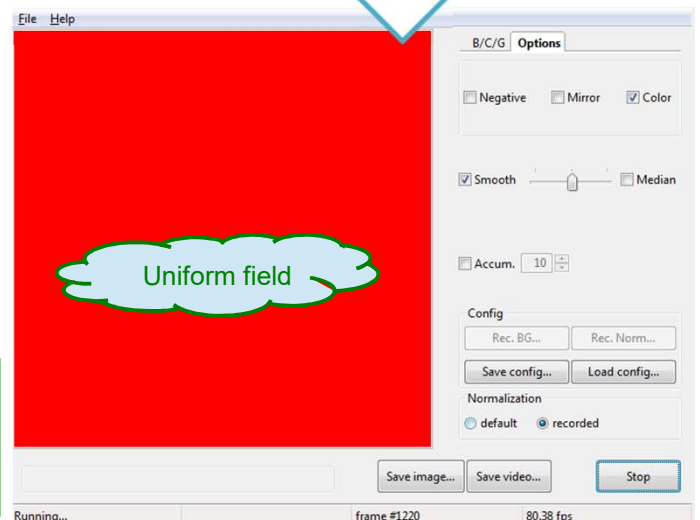
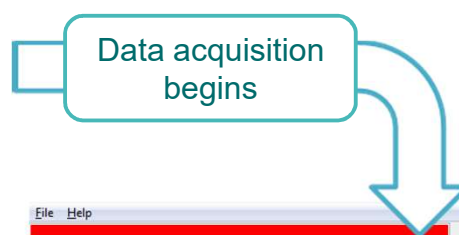
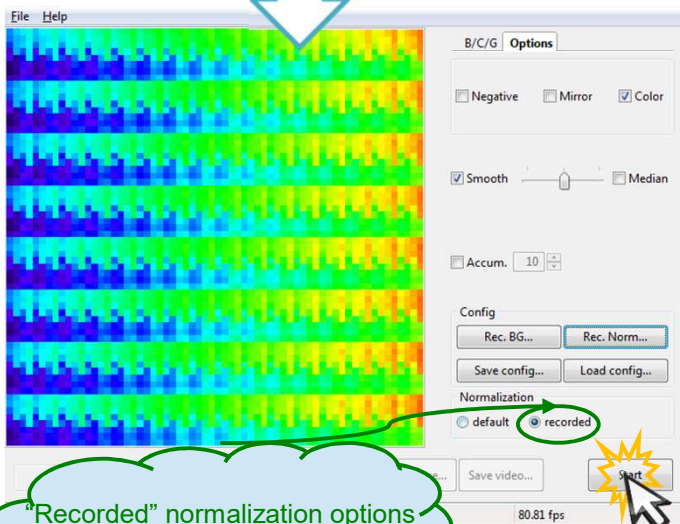

For best results try to arrange source radiation so that it covers entire sensor surface. Software will try and interpolate for poorly lit parts, which would affect performance. It may be useful to switch to longer exposure, but avoid overloads during the recording.

# Software operation

## Background compensation

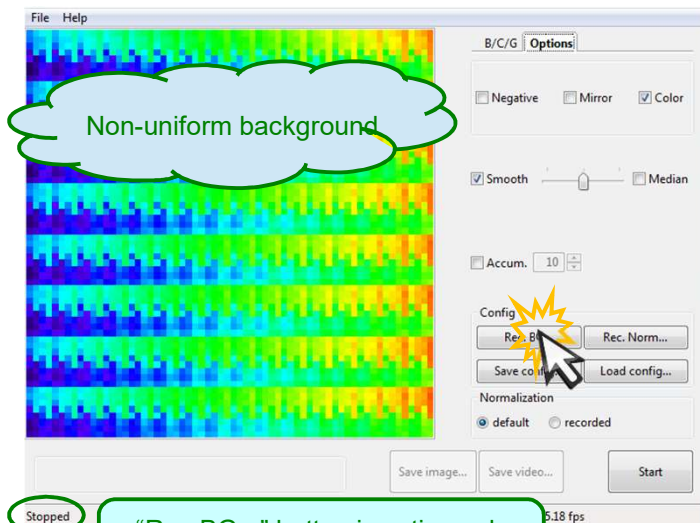

Non-uniform background

Background recording commences

Stopped  
"Rec BG..." button is active only when no acquisition is running.

New background information is applied automatically when data acquisition starts again.

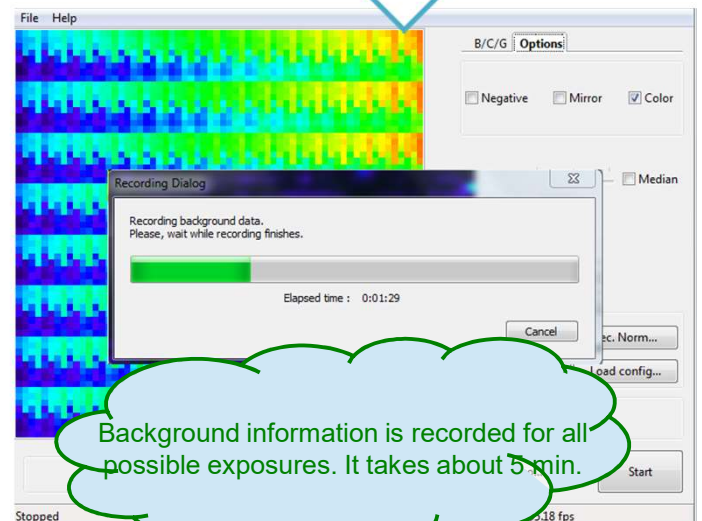

Background information is recorded for all possible exposures. It takes about 5 min.

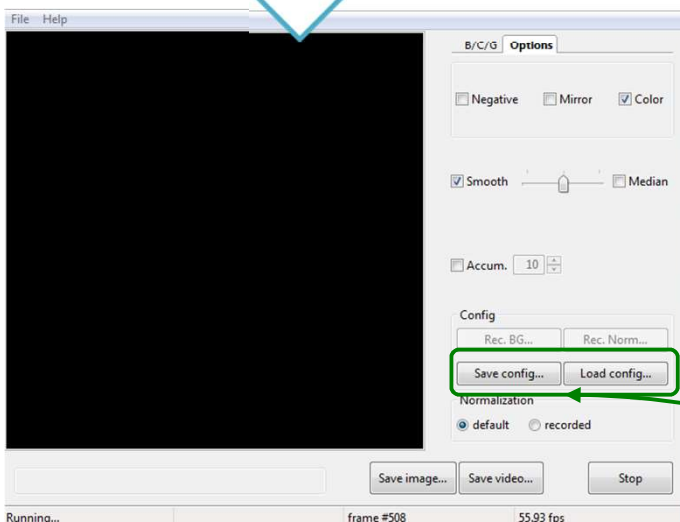

You can save background information using "Save config..." and reload it later using "Load config..." buttons.

Recorded normalization data are saved too.

**Do not forget to switch off radiation source before recording background information if!**



# Software operation

## Saving Image

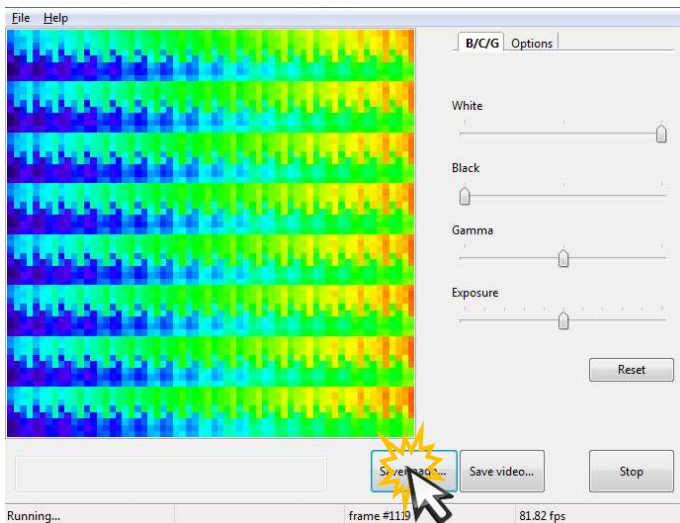

File selection dialog is opened

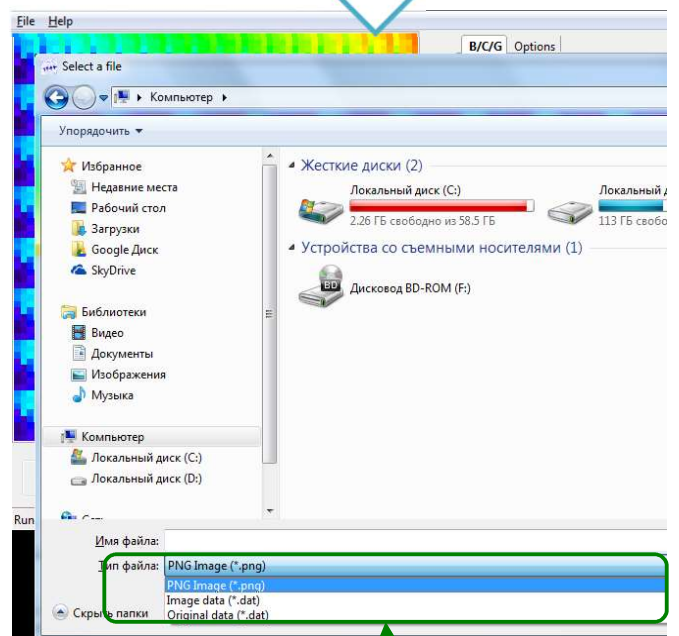

Enter file name, press OK

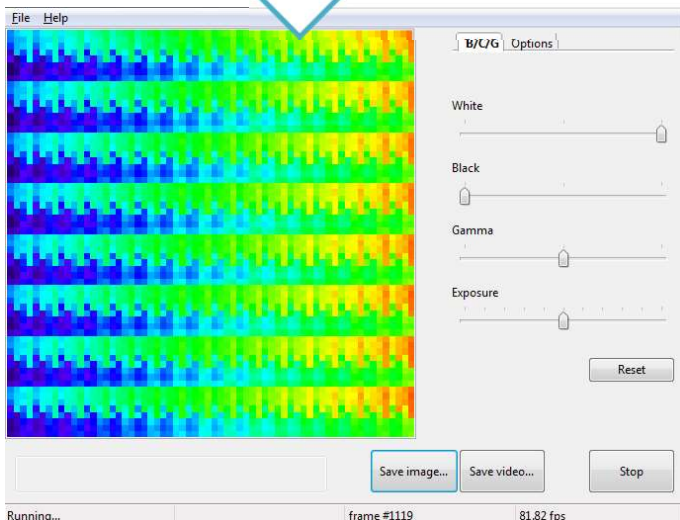

Format options:

- "PNG Image": a copy of what you see on the screen in a common image format;
- "Image data": comma-separated values for the image pixels as floats in 0 to 1 range
- "Original data": the same format as "Image data" but without any brightness/contrast/gamma corrections applied

# Software operation

## Recording video

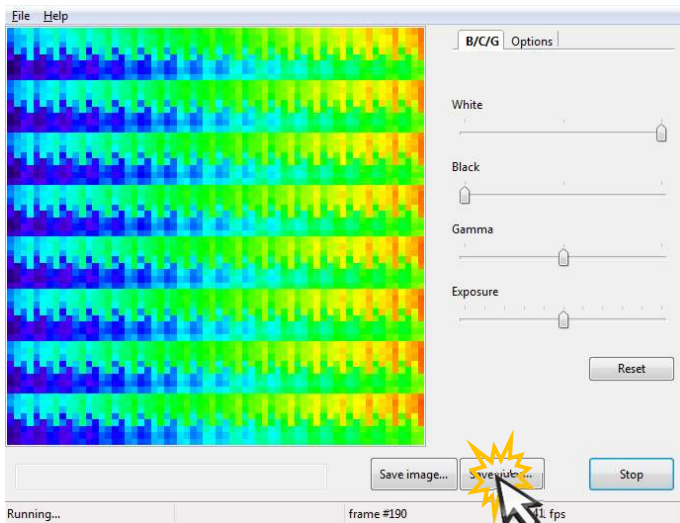

File selection dialog is opened

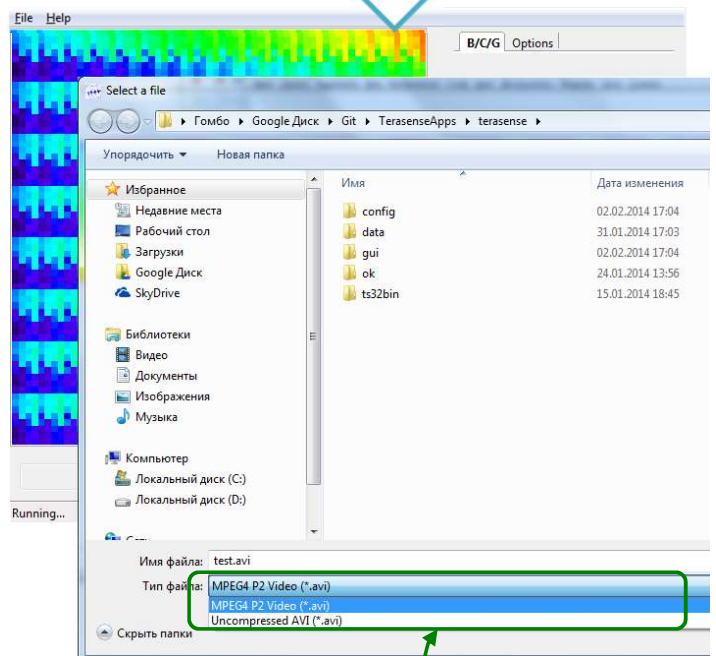

Enter file name, press OK

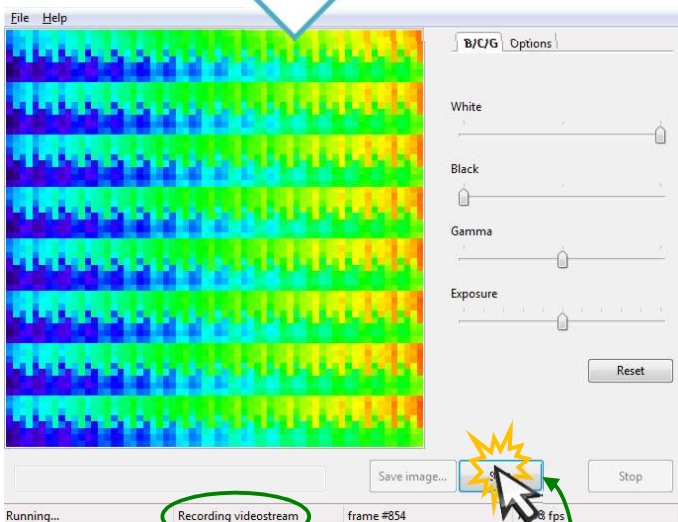

Recording in progress indicator

Click to end recording.

Format options:

- "MPEG4 P2 Video": a common video format playable by most videoplayers;
- "Uncompressed AVI": uncompressed videostream, useful if you want to do data processing.

Generally, video is recorded at actual frame rate, but if it is less than 1 fps, frame rate of the video would be 1 fps.

# Software operation

## Difference mode

- In this mode software displays absolute value of the difference between two consecutive frames. In order for the mode to be useful, you need to modulate radiation source by the sync out signal of the device. The sync signal is +5V TTL with level changes corresponding to frame boundaries (see p.5). You can use equally well use high level as “radiation on” and low as “off” or vice versa.
- In the difference mode background and all its slow variations are automatically canceled out. You can use it in combination with “Accumulation” option (see p.14) to achieve lockin-like operation.

- If you are using one of TeraSense (TM) IMPATT sub-THz generators, you should connect “sync out” output connector of the camera to “MOD IN” input connector of the generator.

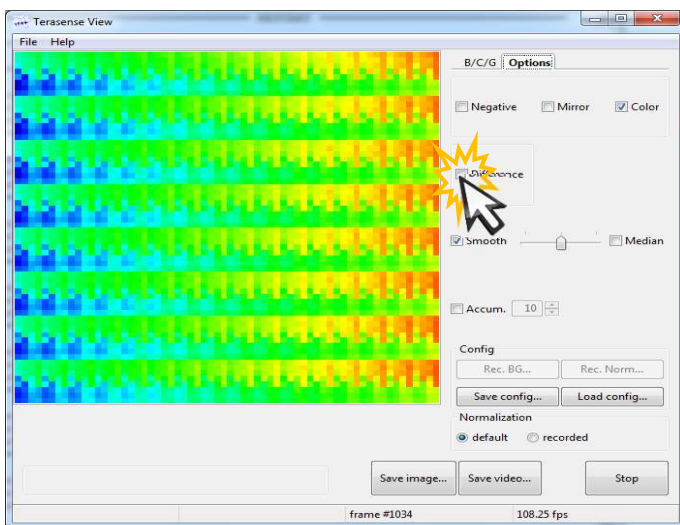

Difference mode is activated

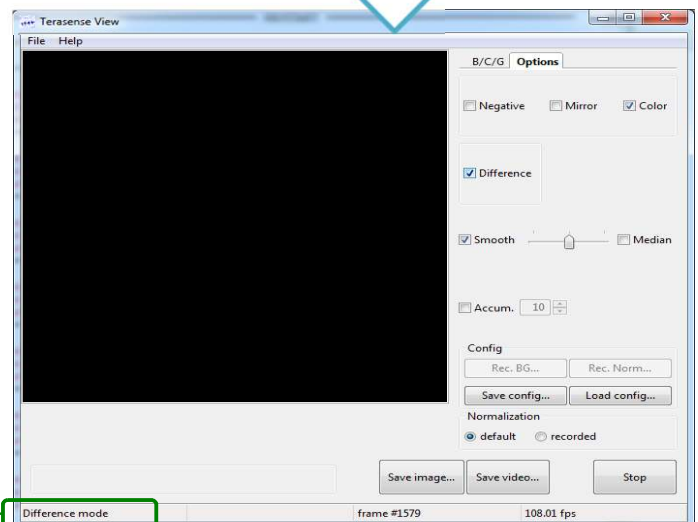

The mode is indicated in the status bar

# Software operation

## Working Area

- You can limit working (and displayed) area of the sensor to its subpart. This option is useful if you want to use recorded normalization, but your source is not covering entire sensor.

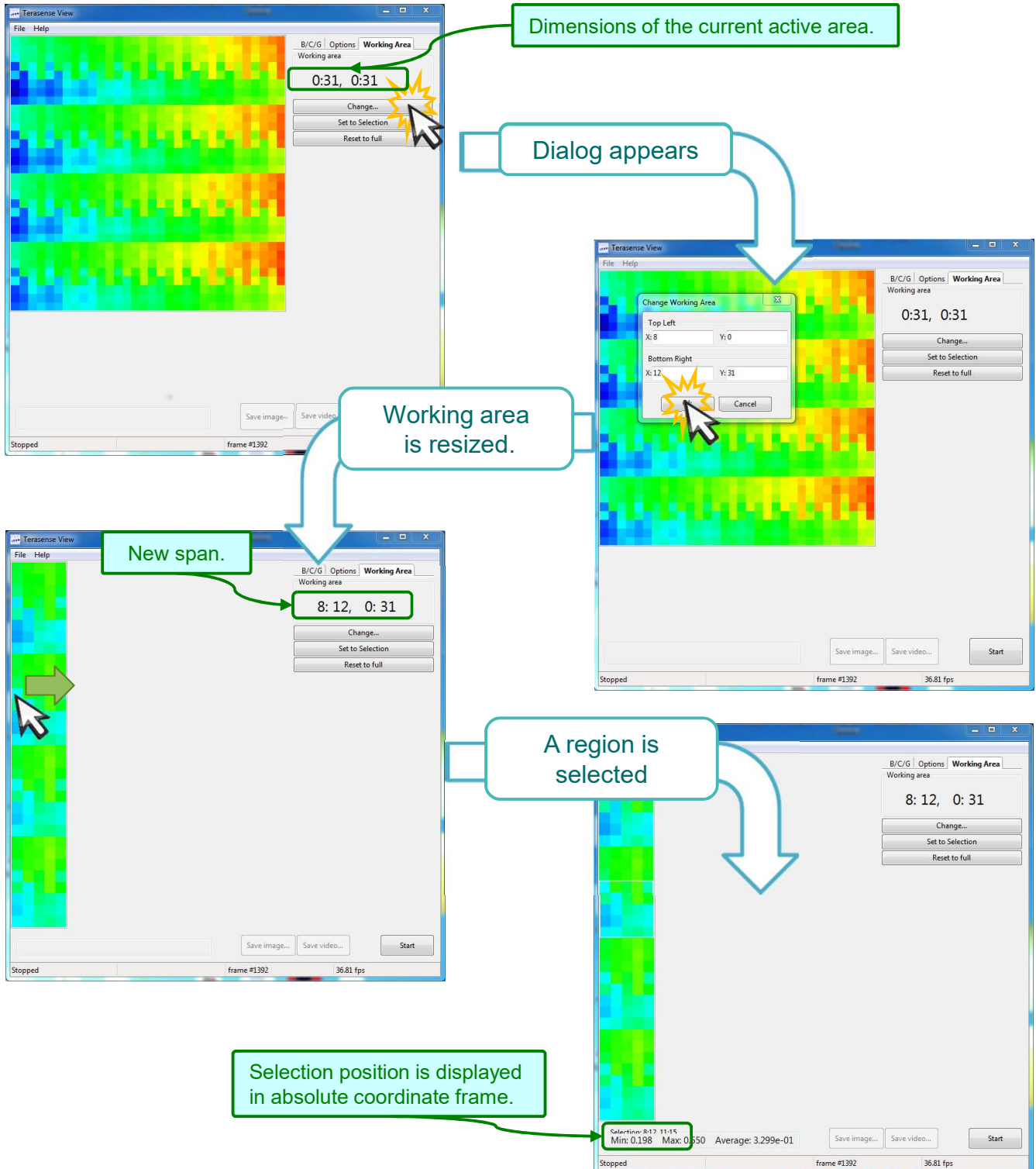

# Software operation

## Working Area

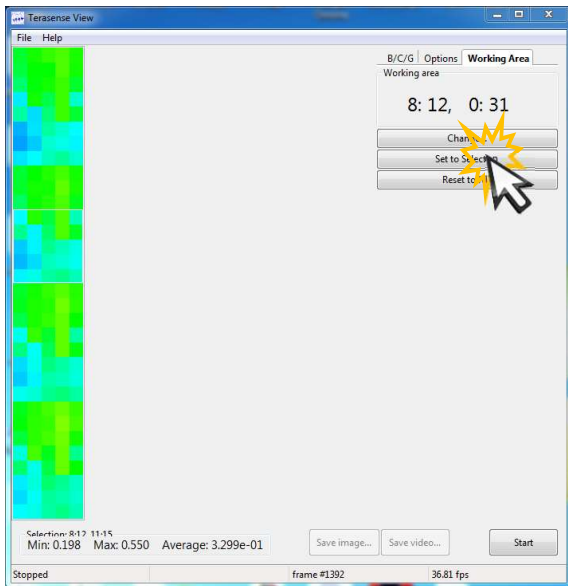

Working area is set to the selected region.

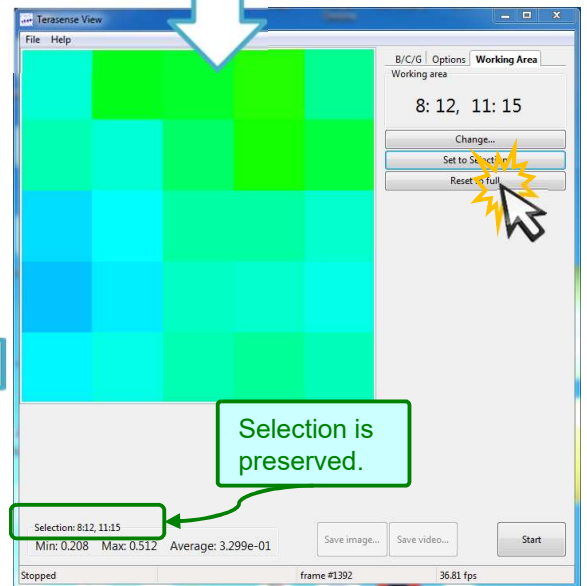

Size of the working area is reset to full image

Selection is preserved.

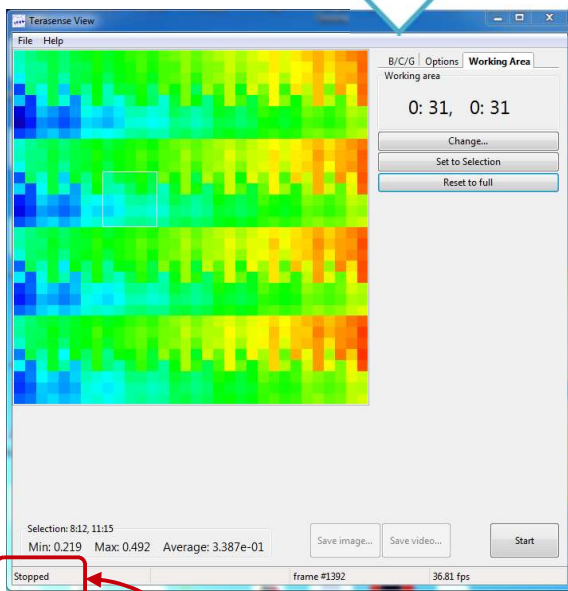

Changes in working area are possible only when acquisition is not running.

---

# Maintenance

- Do not expose the device to excessive heat, do not leave it in direct sunlight for a long time.
- If ambient temperature changes, let the device to come in equilibrium before use.
- Device is not protected against environment. Do not use in very wet or very dusty surroundings.
- PTFE window is soft – be careful not to apply force to it.
- To clean the device use soft cloth. If necessary, moisten it slightly with mild detergent and then dry the device thoroughly. Never submerge it in water!

•

# Troubleshooting

Problem:

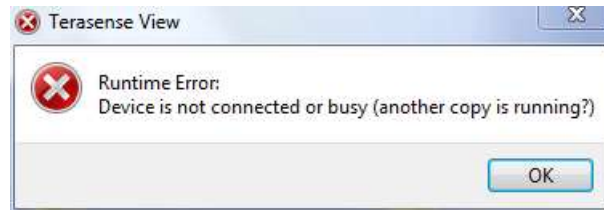

Solution:



Is Opal Kelly XEM6001 present in "Devices and Printers" window?

Yes

No

Use "Alt-Tab" to look for another copy of the Terasense View software (only one copy can be running at a time)

Use "Ctrl-Shift-Esc" to start Windows Task Manager and kill all pythonw.exe processes, then restart Terasense View software.

Check that the camera is connected.

If you are using USB hub (especially, unpowered USB hub), try to connect the camera directly to your PC.

Try to connect the camera to another USB port on your PC.

Disconnect any other USB devices and reconnect the camera.

If the software have crashed (for example, due to the device being disconnected during the run) it may have left a zombie process, which would prevent new copy from running .

TeraSense camera is USB-powered device. Use of non-standard and non-compliant USB accessories may cause deficit of power at the USB port, which would prevent camera form working properly.